

ENCLOSURE AND MOUNTING DIMENSIONS

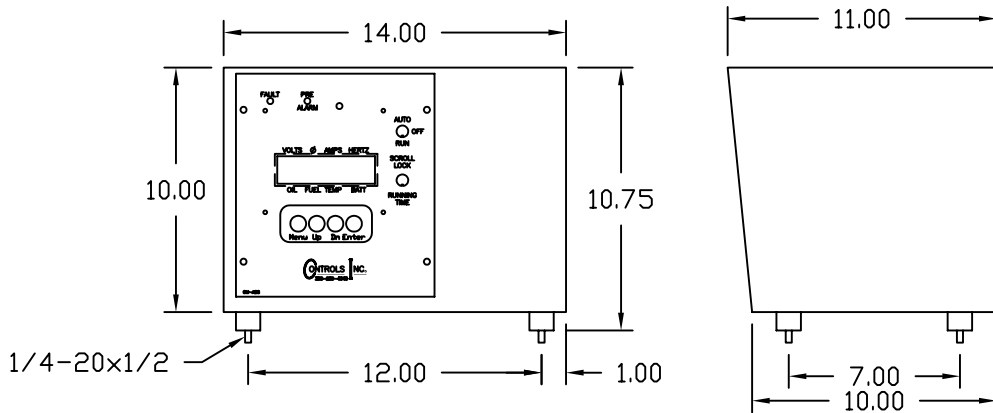

COMMON WIRING CONNECTIONS

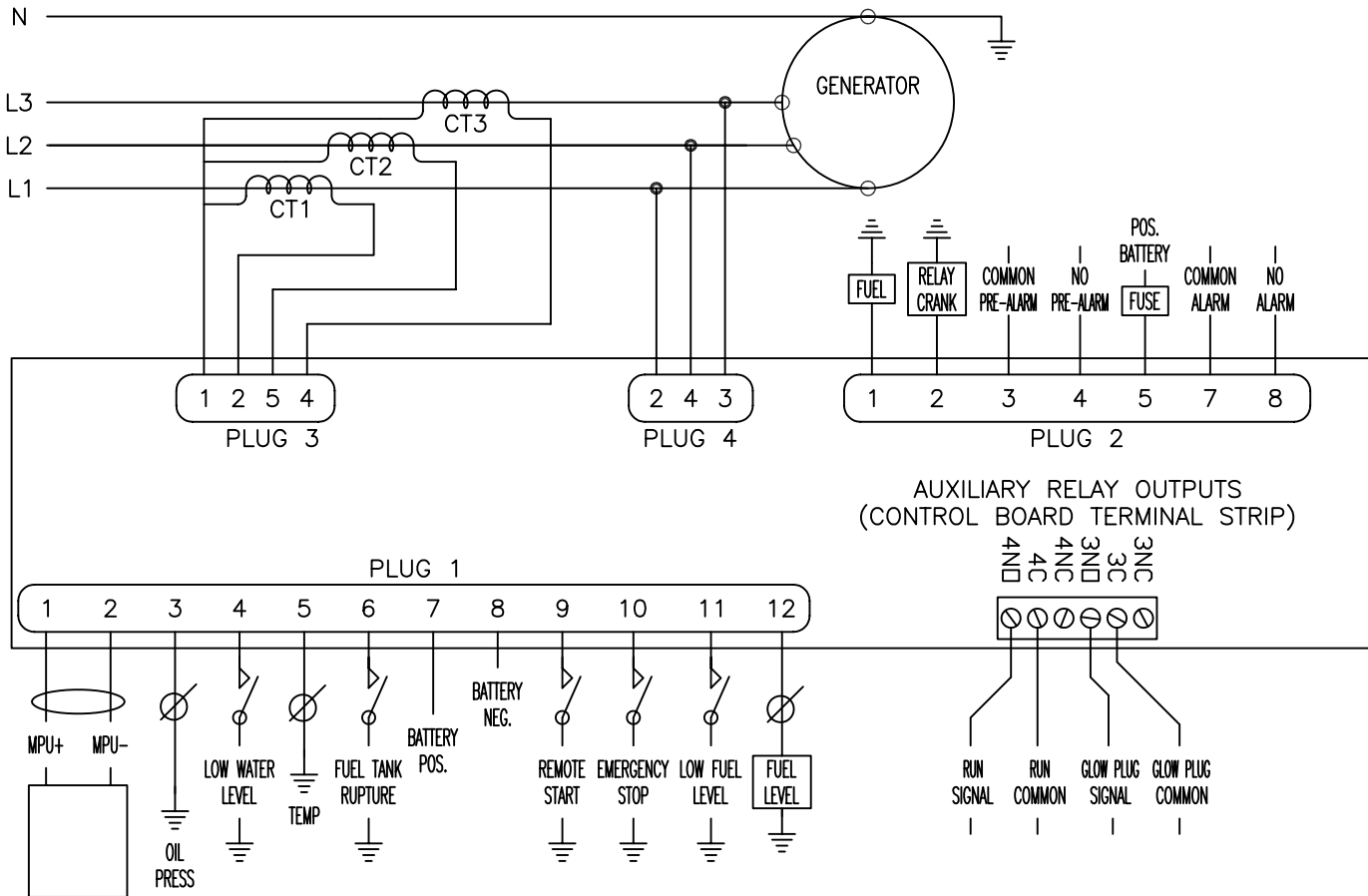

DIP SWITCH FUNCTIONS

SWITCH NUMBER	DIP SWITCH ON PROVIDES:	SWITCH NUMBER	DIP SWITCH ON PROVIDES:
1	RA100 OR RE100	5	GLOW PLUG ENABLE
2	DC VOLT CAL	6	WEAK BATTERY ENABLE
3	NOT USED	7	CT RATIO 1100:5 TO 2000:5
4	ENERGIZE TO STOP	8	CT RATIO 500:5 TO 1000:5