



UNIVERSAL SILENCER

A DIVISION OF NELSON INDUSTRIES, INC.
P.O. Box 411, Stoughton, Wisconsin 53589
608-873-4272 Fax 608-873-4298

SHELLDAMP I SHELL LAGGING

DRAWING		REV.
88-1082		3
DRAWN	DATE	
	4-1-91	

SHELLDAMP I shell lagging is available on all types and sizes of blower silencers and engine silencers. The design of the lagging treatment has been standardized and is installed at the time the silencer is fabricated. (If a normally-stocked unit is to be treated with **SHELLDAMP I**, an extra handling charge applies — see Price List AG-13.)

SHELLDAMP I shell lagging greatly reduces shell noise (shell ring) by a proven design that absorbs some sound energy and reflects some back into the silencer with acoustic insulation and an impervious cover. The design consists of a generous layer of high-density, long-strand, high-temperature fiberglass matting which is applied to the silencer shell. The insulation is compressed and retained with a heavy gauge steel cover. (The treatment increases outside diameter of silencer approximately 3/4"). This is a highly effective means of treating shell noise, resulting in a net reduction of 10 - 15 dB(A). The rugged nature of the design permits the silencer to be shipped and handled with only usual care to avoid damage — no special packaging is required.

If mounting legs or other appurtenances are required, additional reinforcement is provided at load-bearing and welding points and a moderate additional charge applies for this feature.

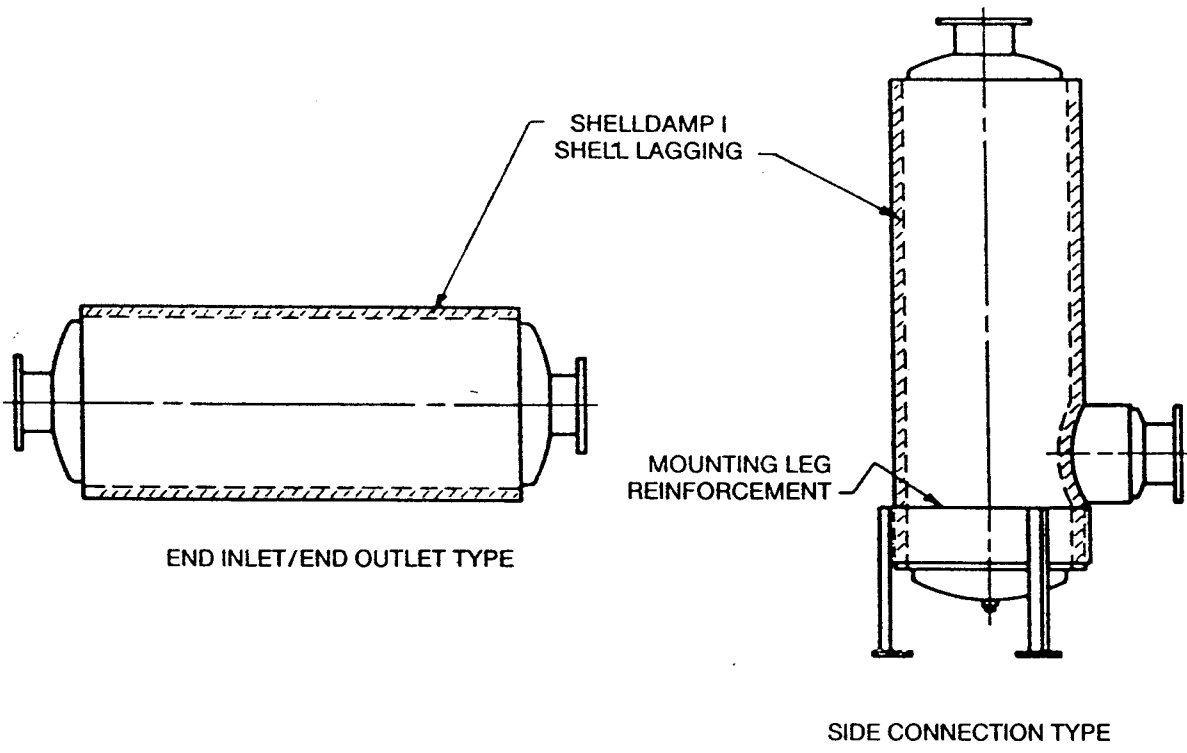

(Supersedes Rev. 2, dated 1-13-84)